

# Eclipse Programmable Rotary Actuator

Model PRA6  
Version 1

Parameter	Description
Power Supply	120 VAC (+10%, -15%), 50/60 Hz or 230 VAC (+10%, -15%), 50/60 Hz Internal power consumption: 5VA
Operating Temperature	-20 to +60°C (0 to 140°F)
Storage Temperature	-25 to +65°C (-10 to 150°F)
Humidity	5 to 95% RH non-condensing
Environment	NEMA 4
Inputs, Analog	4 - 20 mA @ 250Ω impedance; 0 to 10Vdc @ 200KΩ impedance
Inputs, Digital (Isolated Contacts)	Force to high position; force to low position; disable setting codes
Shaft Rotation	Adjustable, 0 to 90° maximum
Minimum Step	1°
Shaft Rotation Direction	Selectable: clockwise or counter-clockwise
Keypad Orientation	Four positions
Display Accuracy	± 1.5°
Position Indicator	9/16" high LED, 0 to 90°
Speed	13 seconds nominal for 90° @ 60 Hz
Torque (Stall Protected)	2.3 Nm (20 lbs-in) 3.9 Nm (35 lbs-in) @ stall
Auxiliary Contact Rating	
Resistive Load:	8A
Inductive Load:	2A
Wiring Connectors	Flexible cord connector: 5.8 to 10 mm (0.231 to 0.394 in) OD cable 3/8 inch liquid tight conduit 1/2 inch female NPT adapter
Terminal Connections	0.5 to 1.5 mm <sup>2</sup> (22 to 16 AWG)
Shipping Weight	1.1 kg (2.5 lbs)

- Eclipse reserves the right to change the construction and/or configurations of our products at any time without being obliged to adjust earlier supplies accordingly.

## Mounting Kits and Hardware for the Rotary Actuator

Part Number	QTY	Description
<b>100127</b>		<b>RH-Mounting Kit, Ver. 2 BV with 10mm shaft, 1/2" to 4"</b>
21695	1	Bracket, BV 1/2" to 4" RH
21048	1	Coupling, 0.25" x 10mm
21068	1	Slotted spring pin, 3mm x 20mm, SS
21050	1	Socket head cap screw, M4 - 0.7 x 20mm
15881	1	Screw, M6 - 1.0 x 12mm (bracket to actuator mounting)
20411	2	Screw, M8 x 14
20240	1	Flat washer, M6
90805	2	Flat washer, M8
20244	1	Lock washer, M4
15625	1	Lock washer, M6
15222	2	Lock washer, M8

Part Number	QTY	Description
<b>100128</b>		<b>LH-Mounting Kit, Ver. 2 BV with 10mm shaft, 1/2" to 4"</b>
21696	1	Bracket, BV, 1/2" to 4" LH
21048	1	Coupling, 0.25" x 10mm
21068	1	Slotted spring pin, 3mm x 20mm, SS
21050	1	Socket head cap screw, M4 - 0.7 x 20mm
15881	1	Screw, M6 - 1.0 x 12mm (bracket to actuator mounting)
20411	2	Screw, M8 x 14
20240	1	Flat washer, M6
90805	2	Flat washer, M8
20244	1	Lock washer, M4
15625	1	Lock washer, M6
15222	2	Lock washer, M8

Part Number	QTY	Description
<b>100124</b>		<b>RH-Mounting Kit, Ver. 1 BV with 3/8" shaft, 1/2" to 4"</b>
21695	1	Bracket, BV 1/2" to 4" RH
20697	1	Coupling, 0.25" x 0.375"
21068	1	Slotted spring pin, 3mm x 20mm, SS
19393	2	Hex head cap screw, 5/16-18 x 5/8
15881	1	Screw, M6 - 1.0 x 12mm (bracket to actuator mounting)
19969	2	Set screw, M4 x 6
19262	2	Flat washer, 1/4"
20240	1	Flat washer M6
15306	2	Lock washer, 5/16"
15625	1	Lock washer, M6

Part Number	QTY	Description
<b>100125</b>		<b>LH-Mounting Kit, Ver. 1 BV with 3/8" shaft, 1/2" to 4"</b>
21696	1	Bracket, BV, 1/2" to 4" LH
20697	1	Coupling, 0.25" x 0.375"
21068	1	Slotted spring pin, 3mm x 20mm, SS
19393	2	Hex head cap screw, 5/16-18 x 5/8
15881	1	Screw, M6 - 1.0 x 12mm (bracket to actuator mounting)
19969	2	Set screw, M4 x 6
19262	2	Flat washer, 1/4"
20240	1	Flat washer M6
15306	2	Lock washer, 5/16"
15625	1	Lock washer, M6

Part Number	QTY	Description
<b>100344</b>		<b>Mounting Kit, 6" &amp; 8" BV*</b>
23013	1	Bracket, BV, 6" to 8", perpendicular
23014	1	Coupling, 0.25" x 0.625"
19473	1	Slotted spring pin, 3mm x 20mm, SS
016157	2	Hex screw, 1/2"-13 x 3/4"
15881	1	Screw, M6 - 1.0 x 12mm (bracket to actuator mounting)
19028	2	Set screw, 1/4"-20 x 3/8"
19272	2	Flat washer, 1/2"
20240	1	Flat washer, M6
15625	1	Lock washer, M6

Part Number	QTY	Description
<b>101150</b>		<b>Coupling Kit, 19mm (no bracket)</b>
21048	1	Coupling, 0.25" x 10mm
21068	1	Slotted spring pin, 3mm x 20mm, SS
21050	1	Socket head cap screw, M4 - 0.7 x 20mm
15881	1	Screw, M6 - 1.0 x 12mm (bracket to actuator mounting)
20244	1	Lock washer, M4
15625	1	Lock washer, M6

### Hardware for Rotary Actuator

Part Number	Description
21934	Bracket, BV 1/2" to 1-1/2", perpendicular
21935	Bracket, BV 2" to 2-1/2", perpendicular
21936	Bracket, BV 3" to 4" perpendicular
21024	Bracket, pkg burners, size 2
21025	Bracket, pkg burners, size 3
21026	Bracket, pkg burners, size 4
21027	Bracket, pkg burners, size 5
21028	Bracket, pkg burners, size 6
21029	Bracket, pkg burners, size 7

\* Check torque requirements of your application with 6" and 8" valves. Do not exceed the PRA6 capability.

## Dimensions

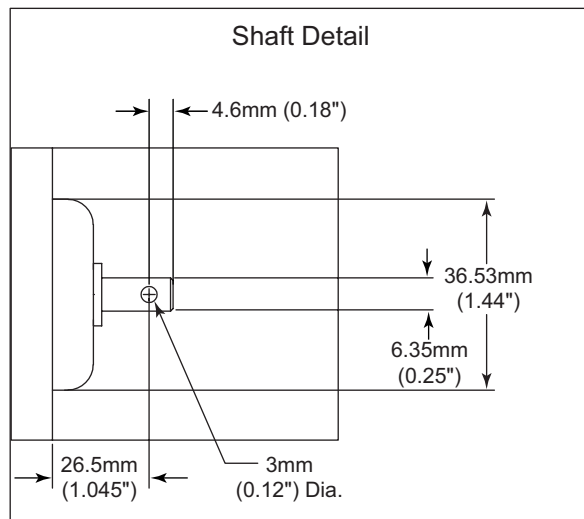
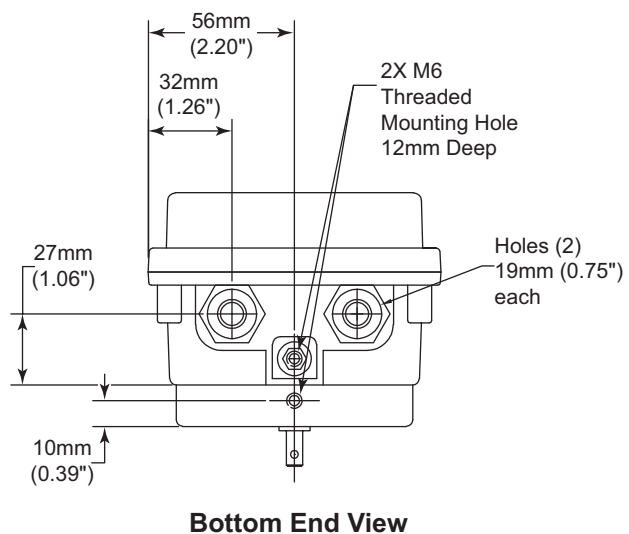
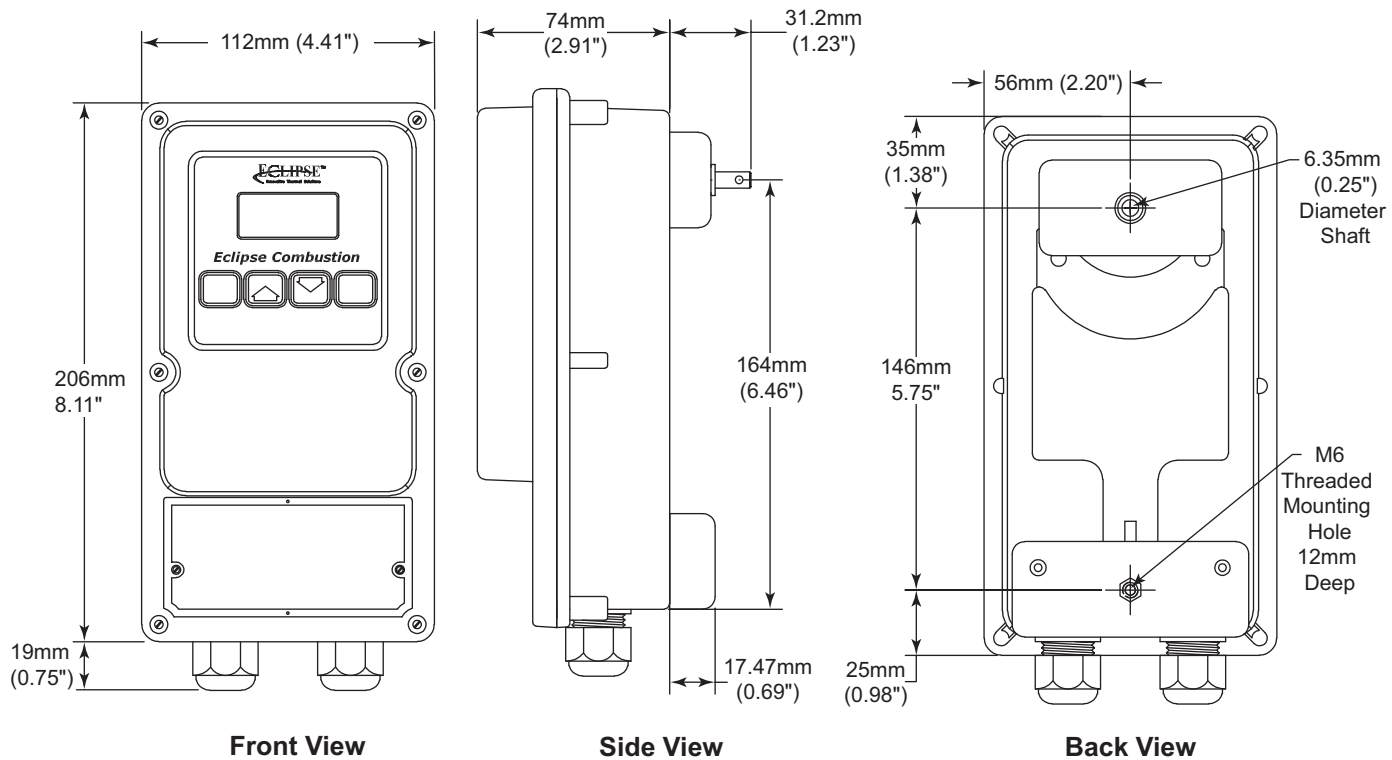

## Keypad Orientation

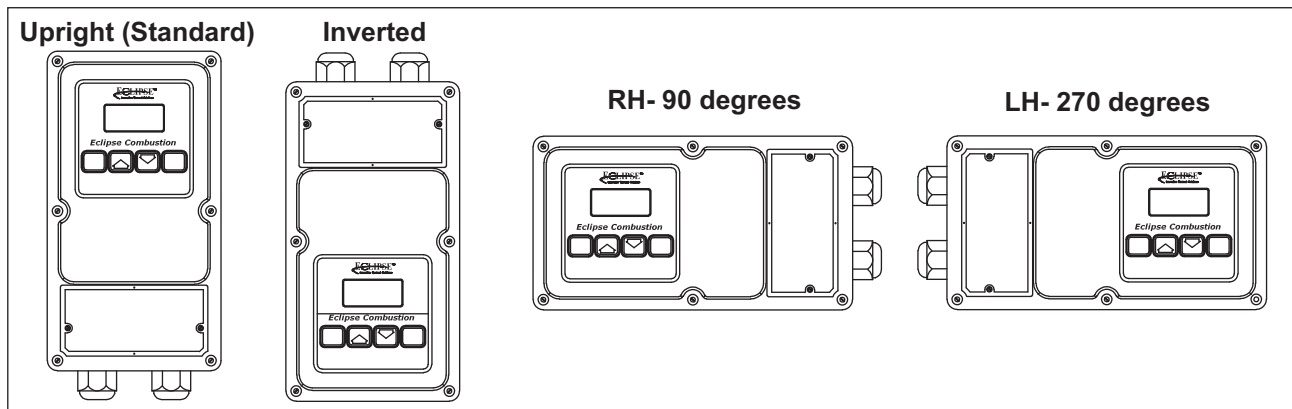

## Electrical Connectors for the Rotary Actuator

Part Number	Description
24258	Connector for cord & cable, liquidtight, PG11 male thread, nylon
21515	Connector for 3/8" liquidtight flexible conduit, PG11 male thread, metal
22647	Adapter with o-ring, male PG11 to female 1/2" NPT, metal
22649	Plug, PG11 male thread, nylon, for sealing unused conduit hole
24361	Locknut, PG11 thread, nylon
21517	Locknut, PG11 thread, metal
22651	O-ring, seal for PG11 thread
22648	Sealing ring, flat washer, for PG11 thread, plastic

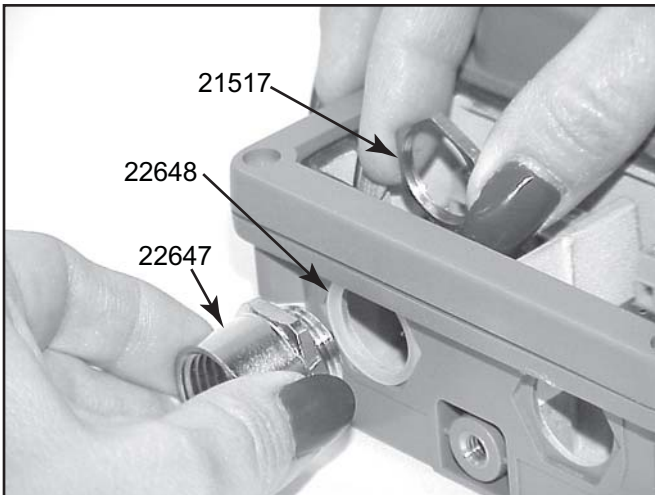

Insert 22648 in location as shown and then assemble 22647 with 21517.

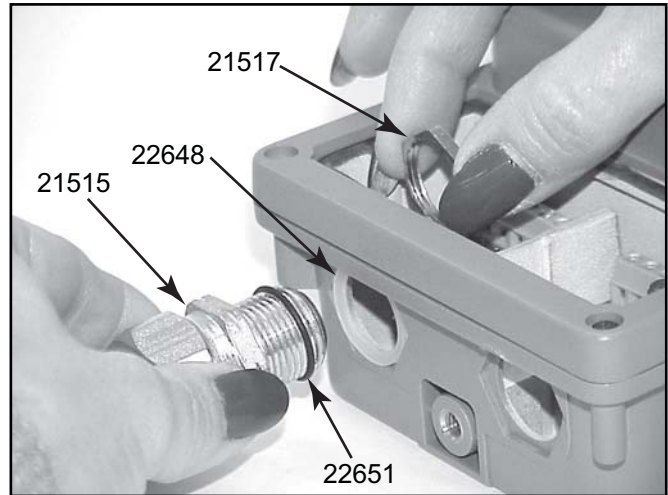

Insert 22648 in location as shown and then assemble 21515 with 21517. Roll 22651 back against hex nut before assembly.

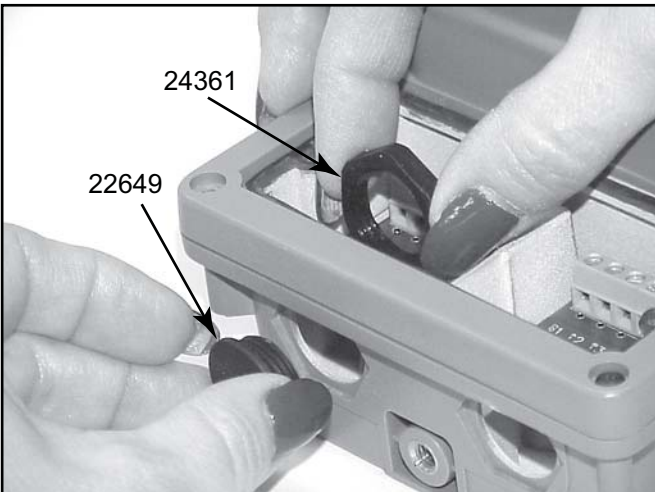



**Offered By:**

Power Equipment Company  
2011 Williamsburg Road  
Richmond, Virginia 23231  
Phone (804) 236-3800  
Fax (804) 236-3882

---

[www.peconet.com](http://www.peconet.com)